

A small sample of the flexibility of PLCs is shown in the following program logic. By reprogramming the T37 contact as a normally closed contact, the function of the circuit is changed to cause the indicator light to turn off only when the timer times out. This function change was accomplished without changing or rewiring I/O devices.

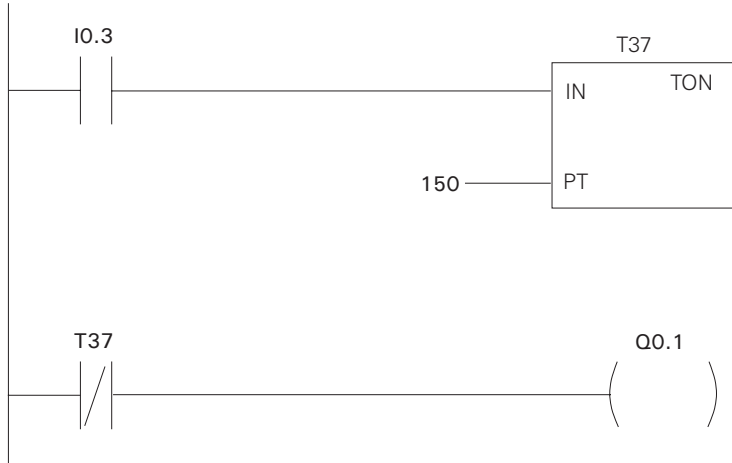

Retentive On-Delay (TONR)

The Retentive On-Delay timer (TONR) functions in a similar manner to the On-Delay timer (TON). There is one difference. The Retentive On-Delay timer times as long as the enabling input is on, but does not reset when the input goes off. The timer must be reset with a RESET (R) instruction.

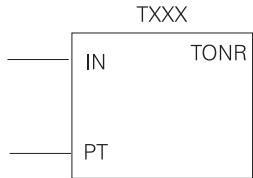

The same example used with the On-Delay timer will be used with the Retentive On-Delay timer. When the switch is closed at input I0.3, timer T5 (Retentive timer) begins timing. If, for example, after 10 seconds input I0.3 is opened the timer stops. When input I0.3 is closed the timer will begin timing at 10 seconds. The light will turn on 5 seconds after input I0.3 has been closed the second time. A RESET (R) instruction can be added. Here a pushbutton is connected to input I0.2. If after 10 seconds input I0.3 were opened, T5 can be reset by momentarily closing input I0.2. T5 will be reset to 0 and begin timing from 0 when input I0.3 is closed again.

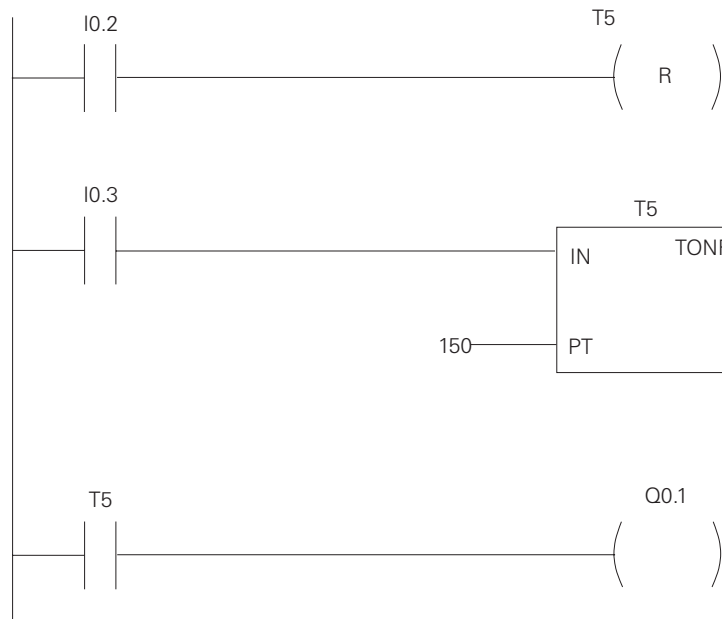

Off-Delay (TOF)

The Off-Delay timer is used to delay an output off for a fixed period of time after the input turns off. When the enabling bit turns on the timer bit turns on immediately and the value is set to 0. When the input turns off, the timer counts until the preset time has elapsed before the timer bit turns off.

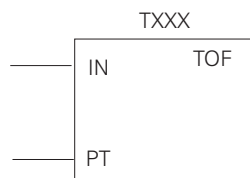

S7-200 Timers

The S7-200s have 256 timers. The specific T number chosen for the timer determines its time base and whether it is TON, TONR, or TOF.

Timer Type	Resolution	Maximum Value	Timer Number
TONR	1 ms	32.767 seconds	T0, T64
	10 ms	327.67 seconds	T1-T4, T65-T68
	100 ms	3276.7 seconds	T5-T31, T69-T95
TON, TOF	1 ms	32.767 seconds	T32, T96
	10 ms	327.67 seconds	T33-T36, T97-T100
	100 ms	3276.7 seconds	T37-T63, T101-T255

Timer Example

In the following example a tank will be filled with two chemicals, mixed, and then drained. When the Start Button is pressed at input I0.0, the program starts pump 1 controlled by output Q0.0. Pump 1 runs for 5 seconds, filling the tank with the first chemical, then shuts off. The program then starts pump 2, controlled by output Q0.1. Pump 2 runs for 3 seconds filling the tank with the second chemical. After 3 seconds pump 2 shuts off. The program starts the mixer motor, connected to output Q0.2 and mixes the two chemicals for 60 seconds. The program then opens the drain valve controlled by output Q0.3, and starts pump 3 controlled by output Q0.4. Pump 3 shuts off after 8 seconds and the process stops. A manual Stop switch is also provided at input I0.1.

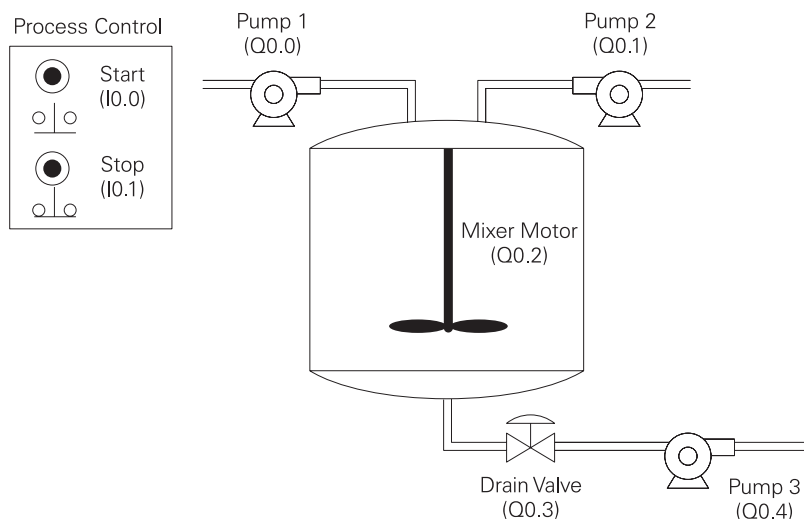

Review 5

1. Analog signals are converted into a _____ format by the PLC.
2. Three types of timers available in the S7-200 are On-Delay, _____ On-Delay, and _____-Delay.
3. The maximum time available on a 100 millisecond time base timer is _____ seconds.
4. A count of 25 on a 10 millisecond time base timer represents a time of _____ milliseconds.
5. There are _____ timers in the S7-200.

Counters

Counters used in PLCs serve the same function as mechanical counters. Counters compare an accumulated value to a preset value to control circuit functions. Control applications that commonly use counters include the following:

- Count to a preset value and cause an event to occur
- Cause an event to occur until the count reaches a preset value

A bottling machine, for example, may use a counter to count bottles into groups of six for packaging.

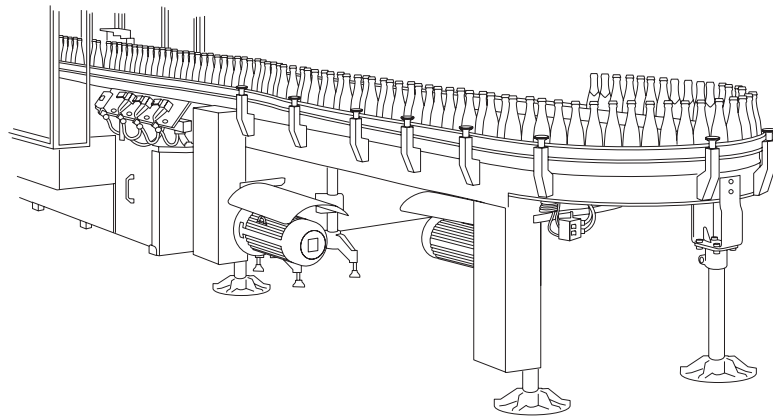

Counters are represented by boxes in ladder logic. Counters increment/decrement one count each time the input transitions from off (logic 0) to on (logic 1). The counters are reset when a RESET instruction is executed. S7-200 uses three types of counters: up counter (CTU), down counter (CTD), and up/down counter (CTUD).

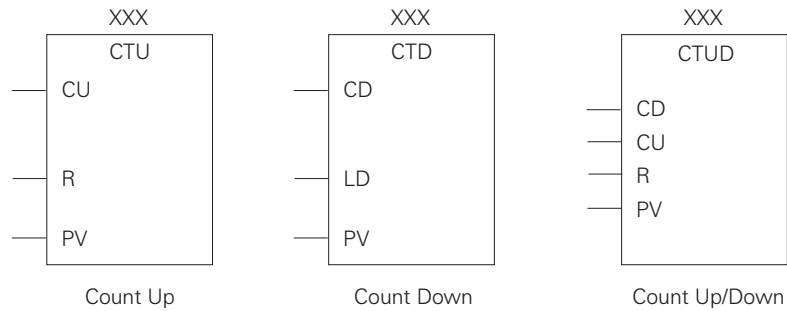

S7-200 Counters

There are 256 counters in the S7-200, numbered C0 through C255. The same number cannot be assigned to more than one counter. For example, if an up counter is assigned number 45, a down counter cannot also be assigned number 45. The maximum count value of a counter is $\pm 32,767$.

Up Counter

The up counter counts up from a current value to a preset value (PV). Input CU is the count input. Each time CU transitions from a logic 0 to a logic 1 the counter increments by a count of 1. Input R is the reset. A preset count value is stored in PV input. If the current count is equal to or greater than the preset value stored in PV, the output bit (Q) turns on (not shown).

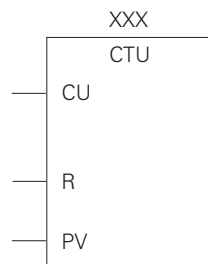

Down Counter

The down counter counts down from the preset value (PV) each time CD transitions from a logic 0 to a logic 1. When the current value is equal to zero the counter output bit (Q) turns on (not shown). The counter resets and loads the current value with the preset value (PV) when the load input (LD) is enabled.

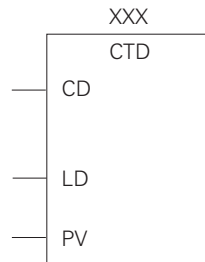

Up/Down Counter

The up/down counter counts up or down from the preset value each time either CD or CU transitions from a logic 0 to a logic 1. When the current value is equal to the preset value, the output QU turns on. When the current value (CV) is equal to zero, the output QD turns on. The counter loads the current value (CV) with the preset value (PV) when the load input (LD) is enabled. Similarly, the counter resets and loads the current value (CV) with zero when the reset (R) is enabled. The counter stops counting when it reaches preset or zero.

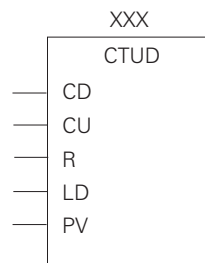

Counter Example

A counter might be used to keep track of the number of vehicles in a parking lot. As vehicles enter the lot through an entrance gate, the counter counts up. As vehicles exit the lot through an exit gate, the counter counts down. When the lot is full a sign at the entrance gate turns on indicating the lot is full.

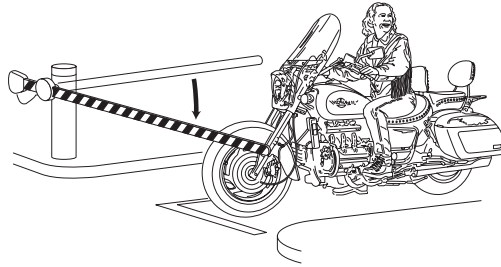

Up/down counter C48 is used in this example. A switch, connected to the entrance gate, has been wired to input I0.0. A switch, connected to the exit gate, has been wired to input I0.1. A reset switch, located at the collection booth, has been wired to input I0.2. The parking lot has 150 parking spaces. This value has been stored in the preset value (PV). The counter output has been directed to output Q0.1. Output 2 is connected to a "Parking Lot Full" sign. As cars enter the lot the entrance gate opens. Input I0.0 transitions from a logic 0 to a logic 1, incrementing the count by one. As cars leave the lot the exit gate opens. Input I0.1 transitions from a logic 0 to a logic 1, decrementing the count by 1. When the count has reached 150 output Q0.1 transitions from a logic 0 to a logic 1. The "Parking Lot Full" sign illuminates. When a car exits, decrementing the count to 149, the sign turns off.

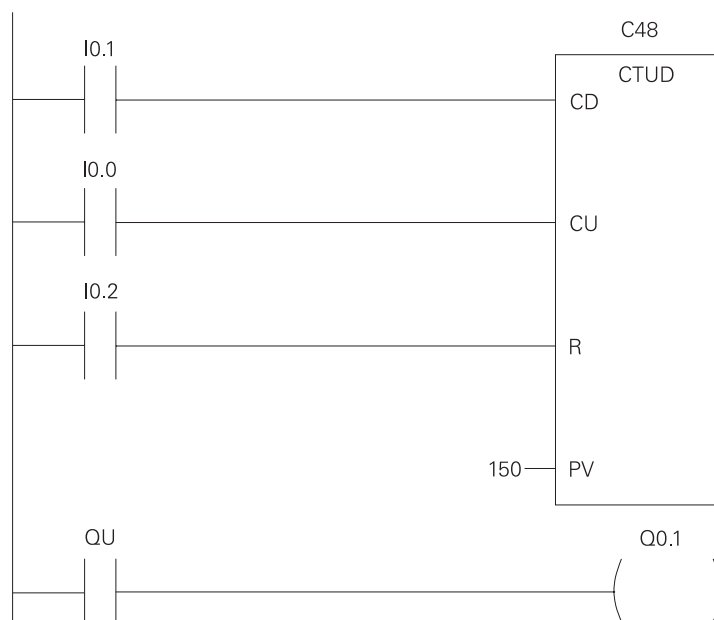

High-Speed Instructions

As discussed earlier, PLCs have a scan time. The scan time depends on the size of the program, the number of I/Os, and the amount of communication required. Events may occur in an application that require a response from the PLC before the scan cycle is complete. For these applications high-speed instructions can be used.

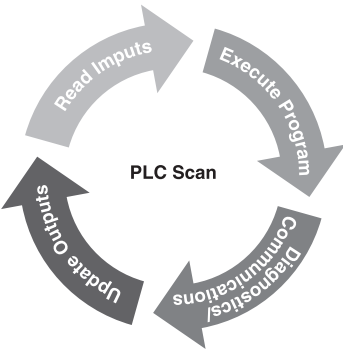

High-Speed Counters

High-speed counters are represented by boxes in ladder logic. CPU 221 and CPU 222 support four high-speed counters (HSC0, HSC3, HSC4, HSC5). CPU 224, CPU 224XP, and CPU 226 support six high-speed counters (HSC0, HSC1, HSC2, HSC3, HSC4, HSC5).

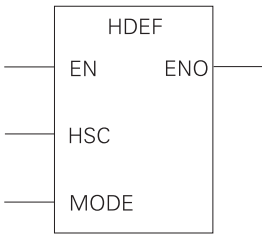

High-Speed Counter Definition

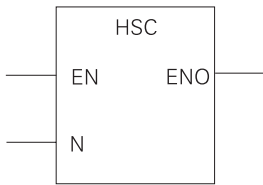

High-Speed Counter

Definition Boxes and High-Speed Counters

The high-speed counter definition boxes are used to assign a mode to the counter. High-speed counters can be defined by the definition box to operate in any of the twelve available modes. It should be noted that not all counters can operate in all of the available modes. Refer to the *S7-Programmable Controller System Manual* for definitions available for each counter. Each counter has dedicated inputs for clocks, direction control, reset, and start where these functions are supported.

Positioning

Positioning is one example of an application that can use high-speed counters. In the following illustration a motor is connected through a starter to a PLC output. The motor shaft is connected to an encoder and a positioning actuator. The encoder emits a series of pulses as the motor turns. In this example the program will move an object from position 1 to position 6. Assume the encoder generates 600 pulses per revolution, and it takes 1000 motor revolutions to move the object from one position to another. To move the object from position 1 to position 6 (5 positions) would take 5000 motor revolutions. The counter would count up 30,000 counts (5000 revolutions x 600 pulses per revolution) and stop the motor.

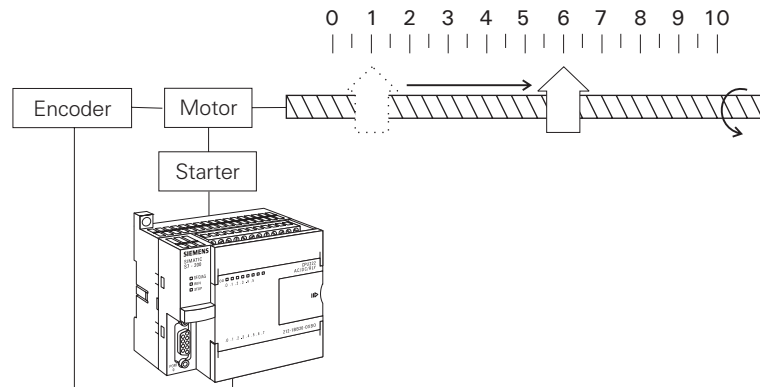

Interrupts

Interrupts are another example of an instruction that must be executed before the PLC has completed the scan cycle. Interrupts in the S7-200 are prioritized in the following order:

1. Communications
2. I/O Interrupts
3. Time-Based Interrupts

PTO

Pulse Train Output (PTO) is used to provide a series of pulses to an output device, such as a stepper motor driver. The PTO provides a square wave output for a specified number of pulses and a specified cycle time. The number of pulses can be from 1 to 4,294,967,295 pulses. PTOs have a 50% duty cycle. This means the pulse is off for the same amount of time it is on. The number of pulses and the cycle time can be changed with an interrupt. In the following example each pulse is on for 500 ms, and off for 500 ms. After four pulses an interrupt occurs which changes the cycle time to 1000 ms.

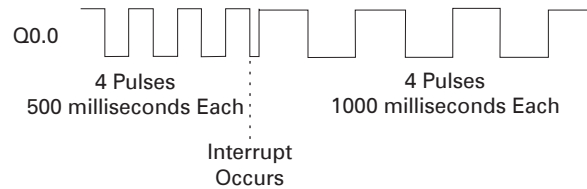

PWM

The Pulse Width Modulation (PWM) function provides a fixed cycle time with a variable duty cycle time. When the pulse width is equal to the cycle time, the duty cycle is 100% and the output is turned on continuously. In the following example the output has a 10% duty cycle (on 10% off 90%). After an interrupt the cycle switches to a 50% duty cycle (on 50%, off 50%).

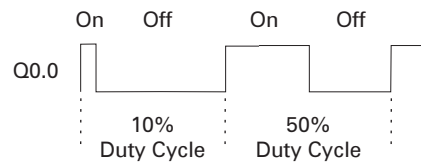

The PWM function can be used to provide a programmable or adjustable control of machine timing. This allows machine operation to be varied to compensate for product variations or mechanical wear.

Transmit

Transmit allows communication with external devices, such as modems, printers, computers, via the serial interface. See the section titled "Connecting External Devices" for examples.

Specialized Expansion Modules

In addition to I/O modules, expansion modules are available for the S7-200 that measure temperature, control positioning applications, and provide various communication functions.

EM 241

In any complex system communication is essential. Modems are electronic devices used for sending and receiving data over long distances. The EM 241 is an expansion module that supports communication between an S7-200 PLC and STEP 7 Micro/WIN via a modem.

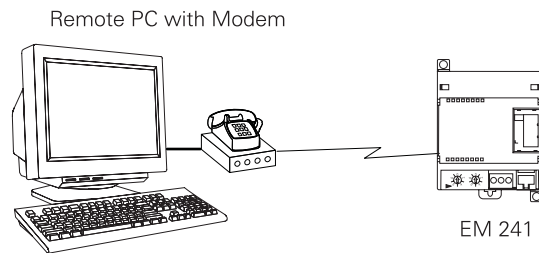

The EM 241 provides an international telephone line interface, supports sending numeric and text paging messages, as well as SMS (Short Message Service) messages to cellular phones. This is useful for remote diagnostics and maintenance, machine control, alarm systems, and general communication functions.

In addition to CPU-to-CPU communication via a telephone line, the EM 241 also supports the ModBus RTU protocol. Protocols are rules that identify how devices should communicate with each other. ModBus RTU is a protocol originally developed by MODICON, which is now part of Schneider Automation. ModBus RTU has been widely used by other companies.

CP 243-1, CP 243-1 IT

Industrial Ethernet provides a proven means of networking computers and a variety of intelligent devices. CP 243-1 and CP 243-1 IT are communication processors used to connect the S7-200 system to Industrial Ethernet.

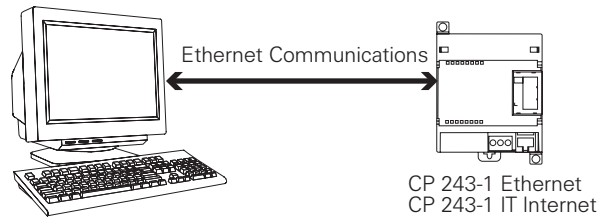

The S7-200 can be remotely configured, programmed, and diagnosed via Industrial Ethernet using STEP 7 Micro/WIN. The S7-200 can also communicate with other S7-200, S7-300, and S7-400 PLCs and a variety of other devices using Industrial Ethernet.

The IT functions of the CP 243-1 IT Internet module simplify the process of setting up a control system that can email diagnostic information or transfer files using Internet protocols.

EM 277

Information flow between intelligent devices such as PLCs, computers, variable speed drives, actuators, and sensors is often accomplished through a local area network (LAN). LANs are used in office, manufacturing, and industrial areas.

In the past, these networks were often proprietary systems designed to a specific vendor's standards. Siemens has been a leader in pushing the trend to open systems based upon international standards developed through industry associations. PROFIBUS-DP and Actuator Sensor Interface (AS-i) are examples of these open networks.

The PROFIBUS-DP EM 277 module allows connection of the S7-200 CPU to a PROFIBUS-DP network as a slave. The CP 243-2 Communication Processor allows communication between AS-i devices and an S7-200.

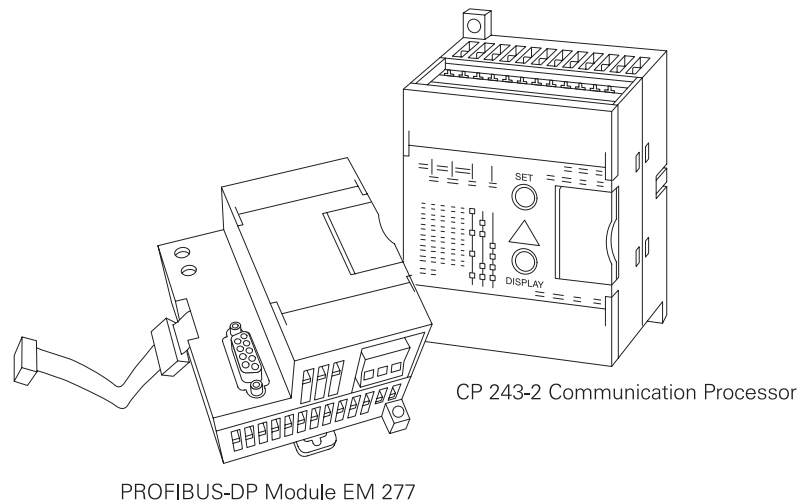

PROFIBUS DP

PROFIBUS DP is an open bus standard for a wide range of applications in various manufacturing and automation processes. PROFIBUS DP works at the field device level such as power meters, motor protectors, circuit breakers, and lighting controls. Through PROFIBUS DP the features of S7-200 PLCs can be used to their full extent within a distributed system. An advantage to PROFIBUS DP is the ability to communicate between PROFIBUS DP devices of different vendors. This provides uniform communication between all SIMATIC devices on the PROFIBUS DP network as well as devices from other manufacturers.

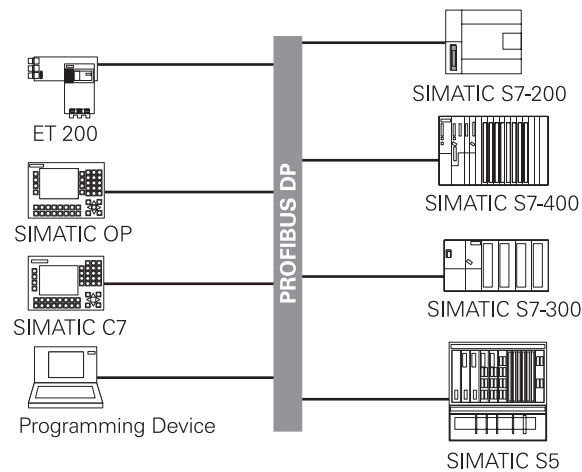

AS-i

Actuator Sensor Interface (AS-i or AS-Interface) is a system for networking binary devices such as sensors. Until recently, extensive parallel control wiring was needed to connect sensors to the controlling device. AS-i replaces complex wiring with a simple 2-core cable. The cable is designed so that devices can only be connected correctly. Several devices can be connected to the cable.

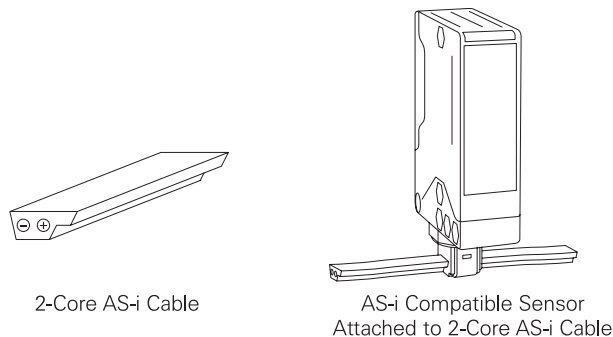

PLCs, for example, use I/O modules to receive inputs from binary devices such as sensors. Binary outputs are used to turn on or off a process as the result of an input.

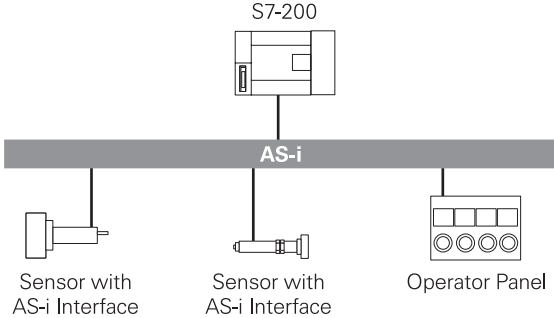

EM 253

Position control describes a range of applications that involve movement with varying degrees of precision. Rotary tables and traversing cars are examples where objects are moved from one position during a product’s manufacturing process.

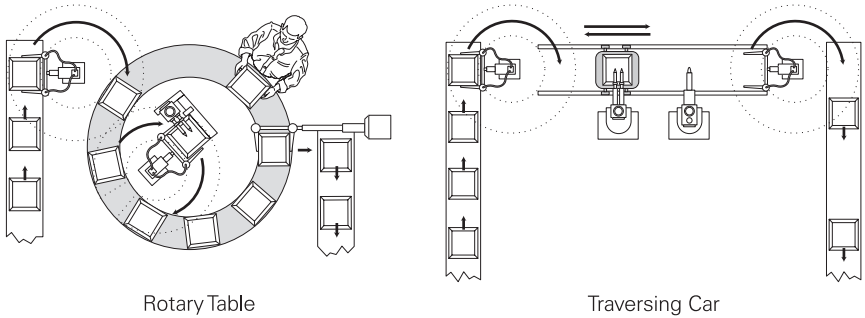

The EM 253 is a positioning module that enables the user to control the speed and position for either stepper motors or servo motors. The EM 253 interfaces between an S7-200 PLC and the stepper/servo motor’s power control module.

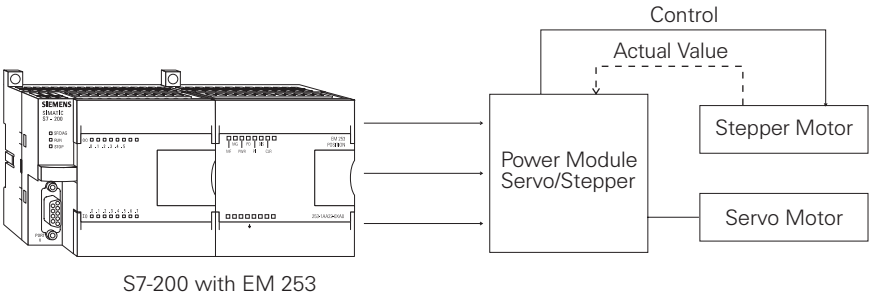

EM 253 Features

The EM 253 provides functionality for single-axis, open-loop position control. Features of the module include:

- High-speed control with a range of 12 - 200,000 pulse per second
- Jerk (S curve) or linear acceleration/deceleration
- Configurable measuring system to enter data as engineering units (such as inches or centimeters) or number of pulses
- Configurable backlash compensation
- Supports absolute, relative, and manual methods of position control
- Continuous operation
- Provides up to 25 motion profiles with up to 4 speed changes per profile
- Four different reference-point seek modes, with a choice of the starting seek direction and final approach direction for each sequence

Web Site

For more information and sales support on the S7-200 visit our web site at:

http://www.automation.siemens.com/s7-200/index_76.htm.

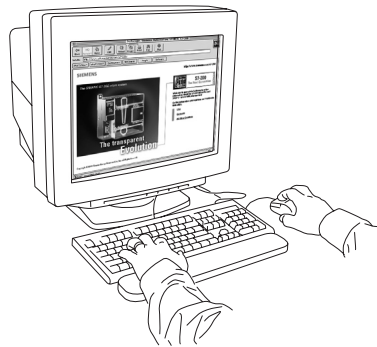

Review 6

1. The S7-200 supports _____ counters.
2. Three types of counters used in S7-200 are _____ , _____ , and _____ .
3. Counters can count to a maximum of _____ .
4. Events that require an action from the PLC before the scan cycle is complete are controlled by _____ instructions.
5. Depending on the counter, there are up to _____ modes available on high-speed counters.
6. The _____ allows communication between AS-i devices and an S7-200.
7. The _____ is a position control module.

Review Answers

Review 1

1) a: input module, b: CPU, c: output module, d: programming device, e: operator interface; 2) 2; 3) 16; 4) 1010, 0001 0000, A.

Review 2

1) discrete; 2) discrete; 3) CPU; 4) Ladder logic; 5) program; 6) program, data, configurable parameter; 7) 1024; 8) firmware; 9) e; 10) RS-485.

Review 3

1) 221, 222, 224, 224XP, 226; 2) b; 3) 2, 7; 4) 8, 6; 5) 14, 10; 6) Q0.3; 7) DIN.

Review 4

1) a: box, b: contact, c: coil; 2) AND Function - a: 0, b: 0, c: 0, d: 1, Or Function - e: 0, f: 1, g: 1, h: 1; 3) I0.0 or Q0.0, and I0.1.

Review 5

1) digital; 2) retentive, off; 3) 3276.7 seconds; 4) 250; 5) 256.

Review 6

1) 256; 2) CTU, CTD, CTUD; 3) $\pm 32,767$; 4) high-speed; 5) 12; 6) CP 243-2 Communication Processor; 7) EM 253.

Final Exam

The final exam is intended to be a learning tool. The book may be used during the exam. A tear-out answer sheet is provided. After completing the test, mail the answer sheet in for grading. A grade of 70% or better is passing. Upon successful completion of the test a certificate will be issued.

1. The component of a PLC that makes decisions and executes control instructions based on the input signals is the _____ .
 - a. CPU
 - b. Input module
 - c. Programming device
 - d. Operator interface

2. One byte is made up of _____ .
 - a. 2 bits
 - b. 8 bits
 - c. 16 bits
 - d. 32 bits

3. The binary equivalent of a decimal 5 is _____ .
 - a. 11
 - b. 100
 - c. 101
 - d. 111

4. An input that is either On or Off is a/an _____ input.
 - a. analog
 - b. discrete
 - c. high-speed
 - d. normally open

5. A programming language that uses symbols resembling elements used in hard-wired control line diagrams is referred to as a _____ .
 - a. ladder logic diagram
 - b. statement list
 - c. network
 - d. PLC scan

6. A type of memory that can be read from but not written to is _____ .
 - a. RAM
 - b. ROM
 - c. firmware
 - d. K memory

15. An S7-200 timer with a time base of 100 ms can count to a maximum value of _____ seconds.
- a. 3.2767
 - b. 32.767
 - c. 327.67
 - d. 3276.7
16. The time base of TON 32 of is _____ ms.
- a. .1
 - b. 10
 - c. 1
 - d. 100
17. The maximum count of an S7-200 up counter is _____.
- a. 32,767
 - b. 65,534
 - c. 98,301
 - d. 1,000,000
18. A/An _____ is used to assign a mode to a high-speed counter.
- a. toggle switch
 - b. interrupt
 - c. PLC scan
 - d. definition box
19. _____ instructions allows communication with external devices, such as modems, printers, and computers.
- a. Transmit
 - b. Interrupt
 - c. High-speed counters
 - d. High-speed outputs
20. _____ is used to temporarily override the input or output status in order to test and debug the program.
- a. Transmit
 - b. Forcing
 - c. Interrupt
 - d. PLC scan

quickSTEP Online Courses

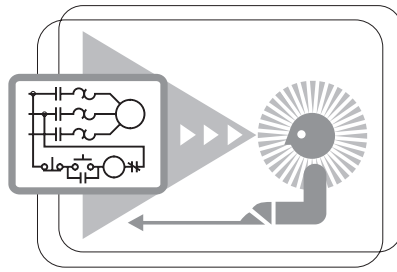

quickSTEP online courses are available at <http://www.sea.siemens.com/step>.

The quickSTEP training site is divided into three sections: Courses, Downloads, and a Glossary. Online courses include reviews, a final exam, the ability to print a certificate of completion, and the opportunity to register in the Sales & Distributor training database to maintain a record of your accomplishments.

From this site the complete text of all STEP courses can be downloaded in PDF format. These files contain the most recent changes and updates to the STEP courses.

A unique feature of the quickSTEP site is our pictorial glossary. The pictorial glossary can be accessed from anywhere within a quickSTEP course. This enables the student to look up an unfamiliar word without leaving the current work area.

